

Model 4001/4004 Instructions

1. Overhead units mount using one hose clamp to clamp the switch panel to the roll bar. Dash units mount with Velcro system supplied.
2. Using 4 screws provided mount the relay board.
3. A clamp is supplied on the switch panel to retain the cable. Swing the support bar aside, insert cable and tighten using Allen wrench or pliers. Plug red tagged cable from switch control into relay board connector. The blue labeled connector is to plug in an optional under hood switch unit (Model 4000F4). Use a small bead of silicone at the junction of the connector plug on the relay board to prevent any loosening of the cable due to vibration. Follow color coding, color markings should be directly over each other.
4. Do NOT use plastic cable ties to secure the ribbon cable to roll bar. Use the included fabric hook and loop cable wraps or use black electrical tape to secure the ribbon cable to the roll bar.
5. Label switches, (first peel off protective plastic film from the switch panel overlay). Using an X-Acto knife or small flathead screwdriver to hold the label will help position the label square in the recess over the light bar. If the label is not installed square, light will leak out around the edges. The label set includes blank labels which can be used to block off the light on any unused switches.
6. Relay board numbers match switch panel numbers. Connect the output leads on the relay board to the corresponding accessory. Use white labels on the relays to match switch functions. The output terminals on the relay board are lugless terminals. Strip approximately ½" of insulation off the wire, loosen the screw, insert bare wire under the clamp and tighten screw.
7. Connect the red 6 gauge cable to battery + .
8. Plug a grounded wire onto the ¼ inch push on terminal marked GND. Switch unit does not require any ground connection.
9. The relay board has a jumper for 12V or 16V operation. It comes installed in the 12V position, for 16V batteries move the jumper to the 16V position.

Set up and use

There are 2 programming switch banks at the end of the unit. On the bank marked "momentary" any switch you desire to be momentary put in the up/off position.

If you choose to use the Master Off feature on the left bank of the programming switches, the first switch "M" must be in the down position. Any switch you wish to go off with the master switch (switch 2) put in the up/off position. All programming switch numbers match the numbers on the front panel switches.

Move the programming switches up or down with a small tip such as a miniature screwdriver. When finished stick black plastic cover patch over cut-out.

Continued....

Troubleshooting

1. It is possible to plug the ribbon cable into the relay board off center to the left or right. If the switch panel does not light up or is not working correctly unplug the ribbon cable from the relay board and plug it in making sure to plug it centered on the connector.
2. The ribbon cable must plug into the switch panel with the cable entering from the rear of the switch panel.
3. Do not unplug the ribbon cable from the switch panel until it is disconnected from the relay board. The relay board sends power to the switch panel and if the cable is unplugged from the switch panel while it is still live, the pins can short out and damage the relay board or cable.
4. If the relay board does not have a good ground the switch panel will function intermittently or not at all. Make sure the male tab marked "GND" is connected to a good ground.
5. Do not use a battery charger as a power supply to "bench test" the unit. Battery chargers can output a pulsing DC which will make the relays buzz and could damage the switch panel. Also note that the switch panel should not be operated when charging the battery.
6. If running a 16V battery make sure to set the jumper to 16V or the switch panel will run warm, and the LEDs will be overly bright and will fail prematurely.
7. If the switch panel lights up red but some or all switches do not turn on, check the following: make sure 12V/16V jumper is set to the correct battery voltage. Make sure the battery is fully charged and in good condition. A weak battery can have enough voltage to light the LEDs on the switch panel but not enough to latch the relays. Also, if the ribbon cable is damaged or the pins are allowed to short to ground it can damage a circuit foil on the relay board.

Nightglow Function

ARC's new black overlay night glow switch panels are designed to provide switch outline visibility in low light conditions; similar to how a battery charges and then gives light back out. You will notice that after coming out of the shipping box the nightglow will be mostly discharged. It will require some 20-30 minutes in ambient light to recharge. The lit LEDs on the switch panel will also charge the nightglow material.

The night glow will become increasingly visible as the ambient light level goes down. An obvious greenish glow will be seen in extremely low light conditions.



Use supplied hook and loop fabric cable straps or electrical tape to secure Ribbon Cable to the roll bar. **DO NOT USE TIE WRAPS!**

Use supplied white plastic retention clip to mount Ribbon Cable to a flat surface.

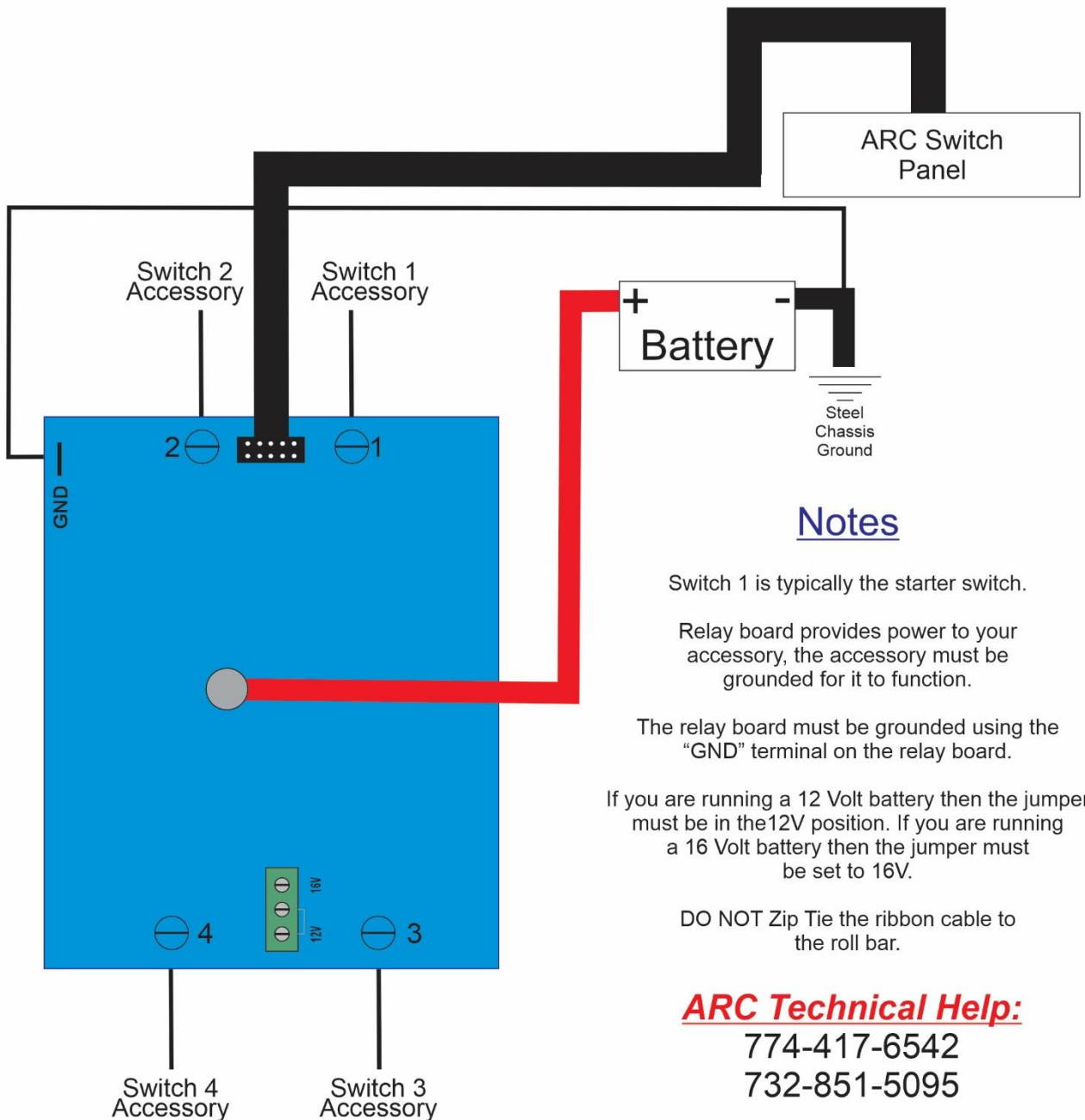
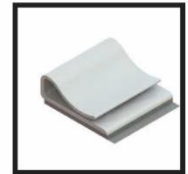

Notes

Switch 1 is typically the starter switch.

Relay board provides power to your accessory, the accessory must be grounded for it to function.

The relay board must be grounded using the "GND" terminal on the relay board.

If you are running a 12 Volt battery then the jumper must be in the 12V position. If you are running a 16 Volt battery then the jumper must be set to 16V.

DO NOT Zip Tie the ribbon cable to the roll bar.

ARC Technical Help:

774-417-6542

732-851-5095